

Lecture :

Super-Kamiokande

(history & technology)

2022/07/12

M.Miura

(Kamioka observatory, ICRR, Univ. of Tokyo)

Contents

1. Why was SK born ?
2. Past, Current and Future of Kamioka observatory
3. Key technology
4. How SK works ?

1. Why was SK born?

- The Standard Model is very beautiful and successful to explain high energy phenomena.
- But there are so many parameters which can not explain by the standard model itself.
- Is it really fundamental theory ?

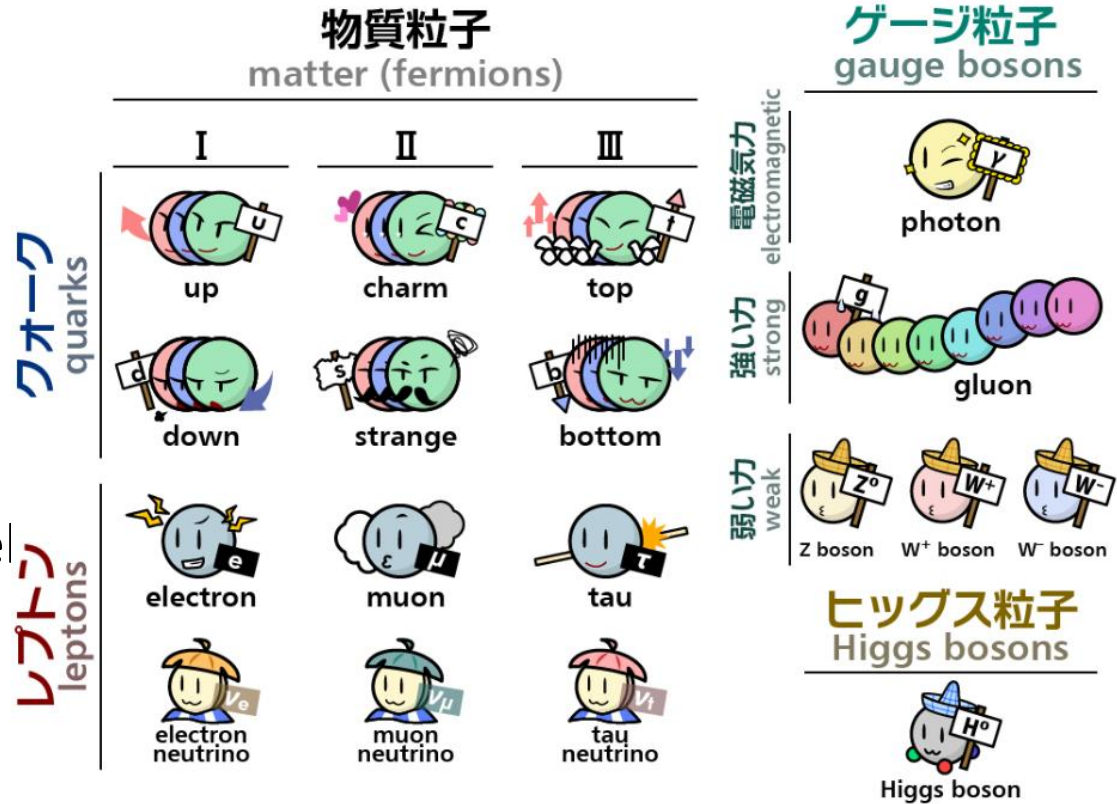

So many actors in the Standard Model theater....

- Strength of three interactions seems to meet at very high energy.
- Grand Unified Theory (GUTs) was proposed to unify three forces.
- If it is true, leptons and quarks could transform each other.
- Proton could be decayed !

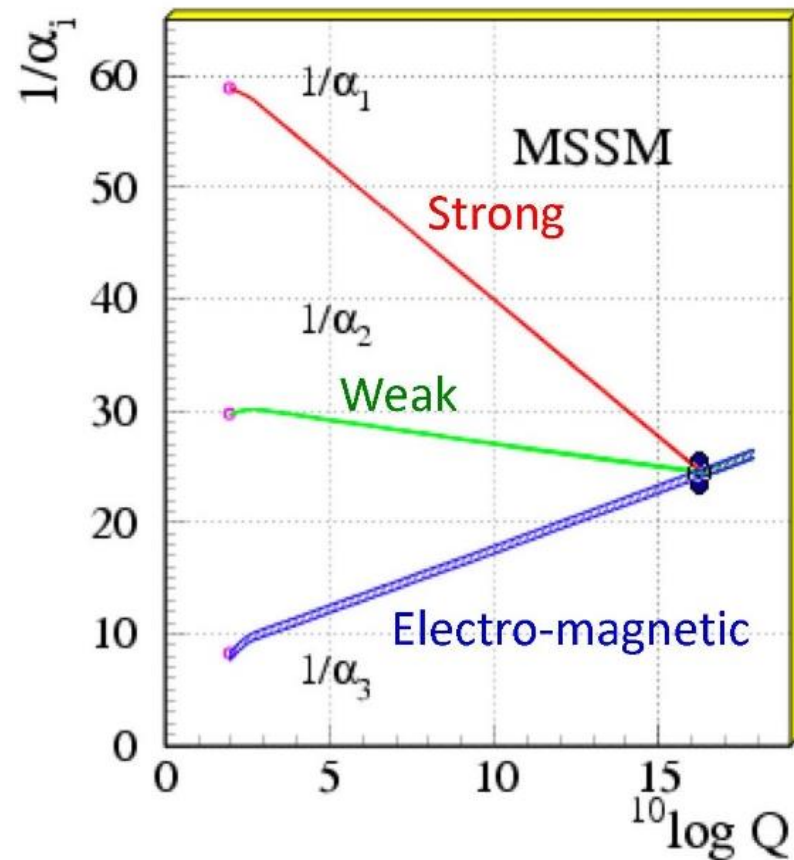

- In the late 1970s, several experiments were proposed for discovery of proton decay.
 - minimal SU(5) prediction: $10^{28} \sim 10^{32}$ years
 - Age of universe: $\sim 1.3 \times 10^{10}$ years
 - It is impossible to continue observation one proton for such long time, but it is equivalent to study large number of proton in short time.
 - 1kt detector expected $10 \sim 10^3$ decays/year.
- Like gold rash, many large detectors were build.
- Two types of detector came into fashion (the 1st generation).

Fine-grained iron calorimeter

- Excellent in track reconstruction.
- Cost per ton were expensive.
- KGF (India), Soudan I,II (Minnesota), NUSEX (Italy/France)

Water Cherenkov detector

- Good momentum resolution and PID.
- Cheaper and easier to build larger detectors.
- HPW (Harvard-Purdue-Wisconsin), IMB (Irvine, Michigan, Brookhaven), **Kamiokande**

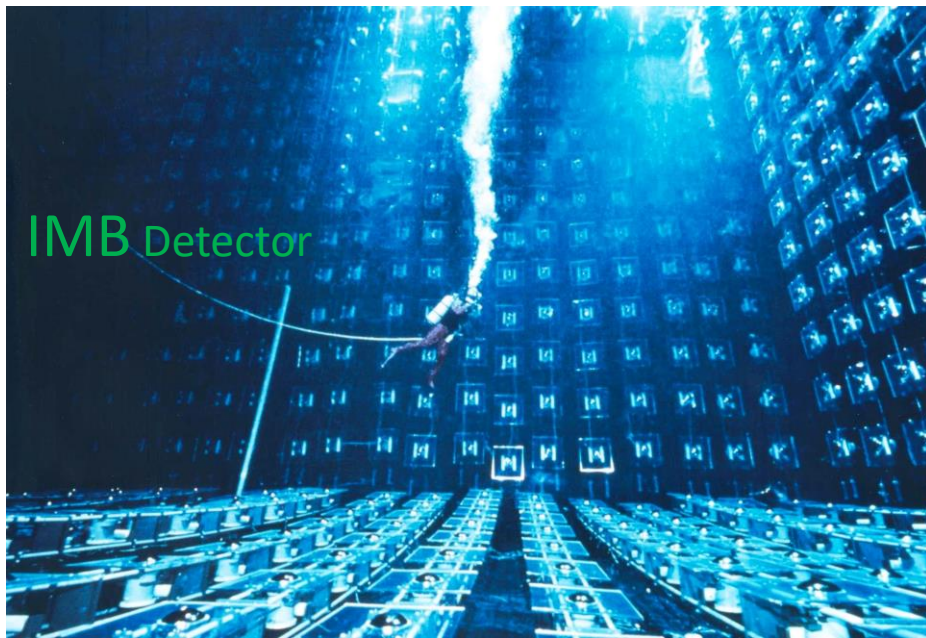

Results of Water Cherenkov detector

Detector	Period	Mass (ton)	Limit ($e^+\pi^0$, 10^{30} yr)
HPW-I	1983-1984	680	1.0
Kamiokande	1983-1997	1040	260
IMB	1982-1992	3300	540

Results of Iron calorimeter

Detector	Period	Mass (ton)	Limit ($e^+\pi^0$, 10^{30} yr)
NUSEX	1982-1998	110-130	15
Frejus	1984-1988	550	70
Soudan I	1981-1990	16-24	1.3



**Could not find evidence.
Need more volume !**

- By the way, background events for proton decay are induced events by neutrino.
- Need to study neutrino (finally, they became famous as neutrino detector rather than proton decay detector).
- There were unexpected results on neutrino.
 - Solar neutrino problem
 - Atmospheric neutrino problem
- Observed Super Nova neutrino in 1987.
- To investigate in detail, also larger detector was needed.
- Kamikande and IMB group collaborated to build Super-Kamiokande.

2. Past, Current and Future

Location: Kamioka mine, Japan. ~1000 m under ground.
Size: 39 m (diameter) x 42 m (height), 50kton water.
Optically separated into inner detector (ID) and outer detector (OD, ~2.5 m layer from tank wall.)
Photo device: 20 inch PMT (ID), 8 inch PMT (OD, veto cosmic rays, ~1/3 comes from IMB).
Mom. resolution: 3.0 % for e 1 GeV/c (4.1%: SK-2).
Particle ID: Separate into EM shower type (**e-like**) and muon type (**μ -like**) by Cherenkov ring angle and ring pattern.

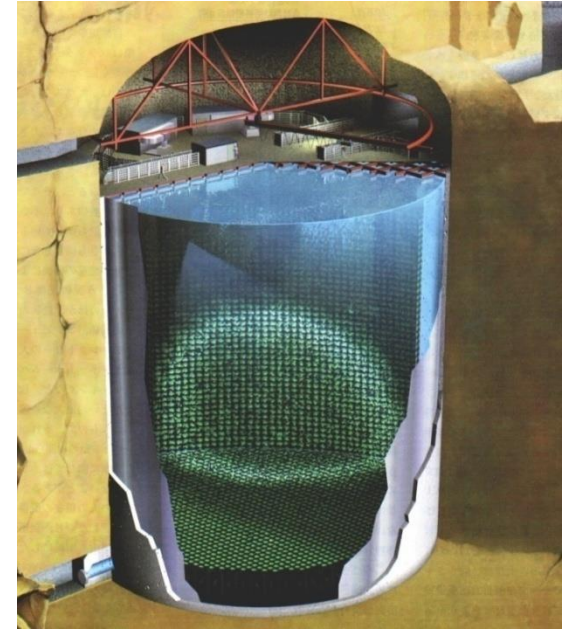

Physics targets of Super-Kamiokande

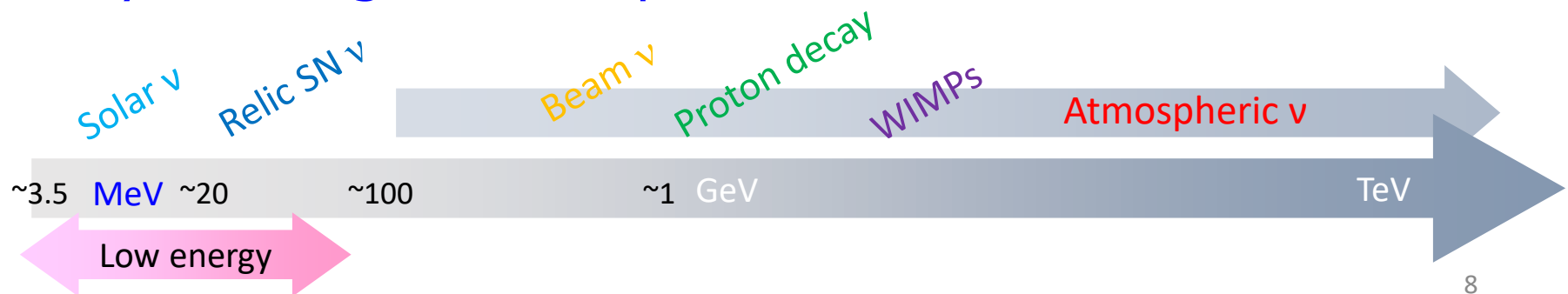

Underground laboratories

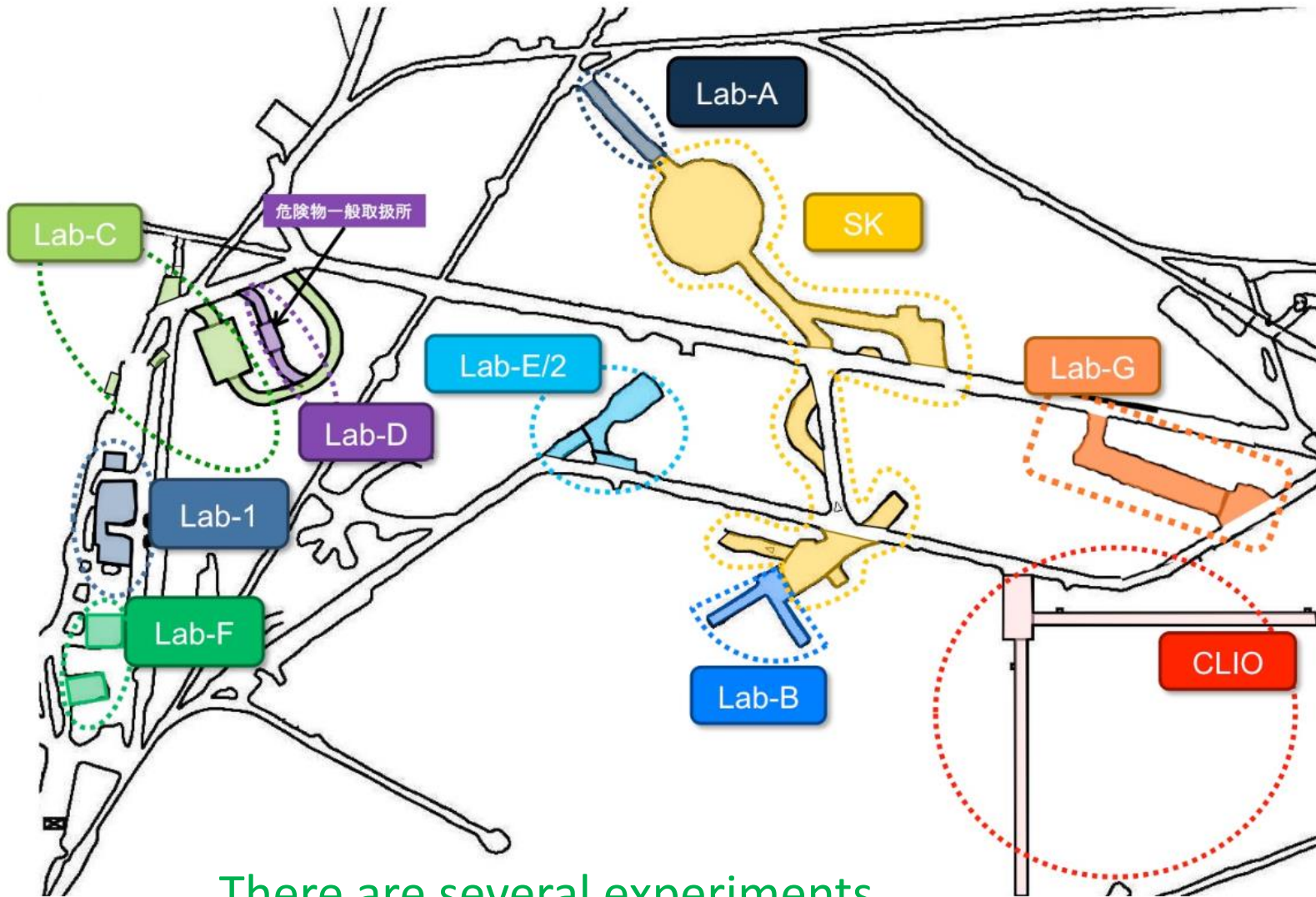

There are several experiments.

Super-Kamiokande collaboration

- Host: Institute for Cosmic Ray Research (**ICRR**), University of Tokyo
- **11 countries**: Japan, US, Canada, China, Korea, Poland, Spain, UK, Italy, France, **and Vietnam (IFIRSE) from 2021 !**
- **~200 members**

Amazingly, SK still runs stably more than 20 years.

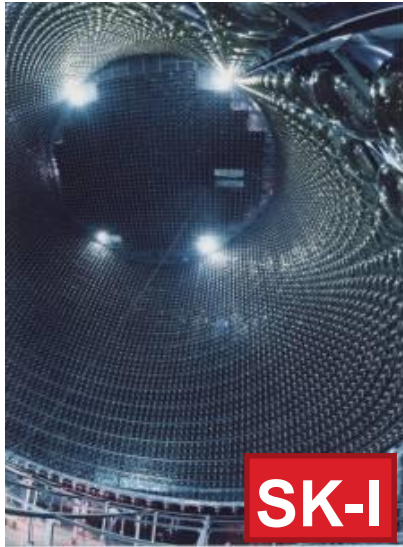

SK-I

11146 ID PMTs
(40% coverage)

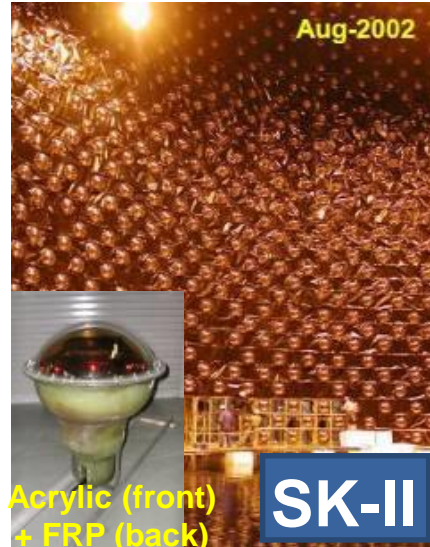

SK-II

5182 ID PMTs
(19% coverage)

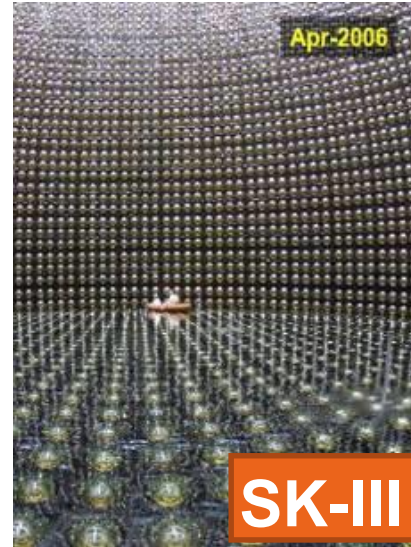

SK-III

11129 ID PMTs
(40% coverage)



SK-IV

Electronics
Upgrade



SK-I

Found ν oscillation

Accident

SK-II

Full reconst.

SK-III

New electronics

SK-IV

Nobel prize

Most famous result: Evidence of neutrino oscillation

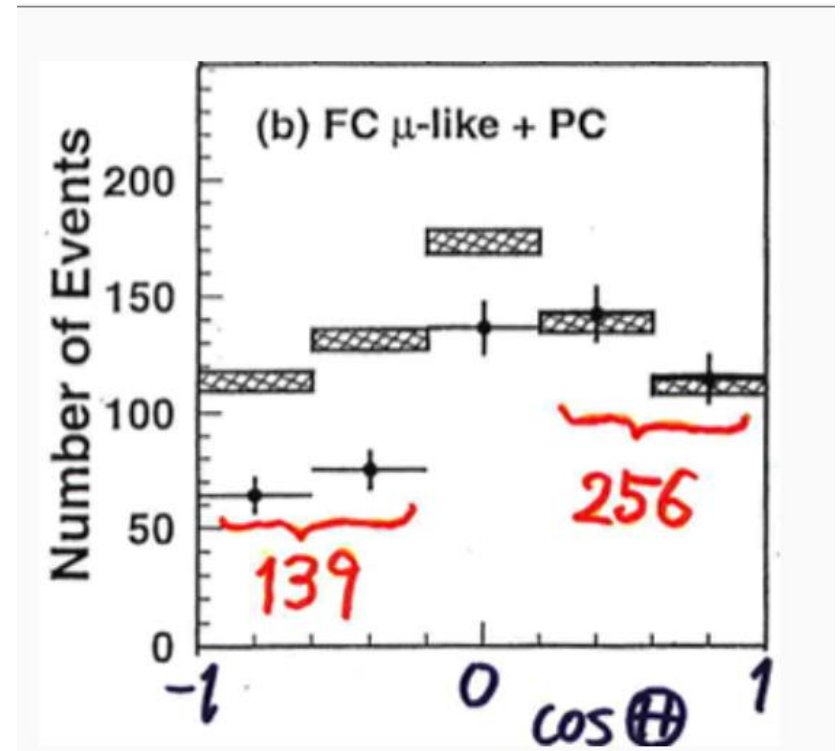
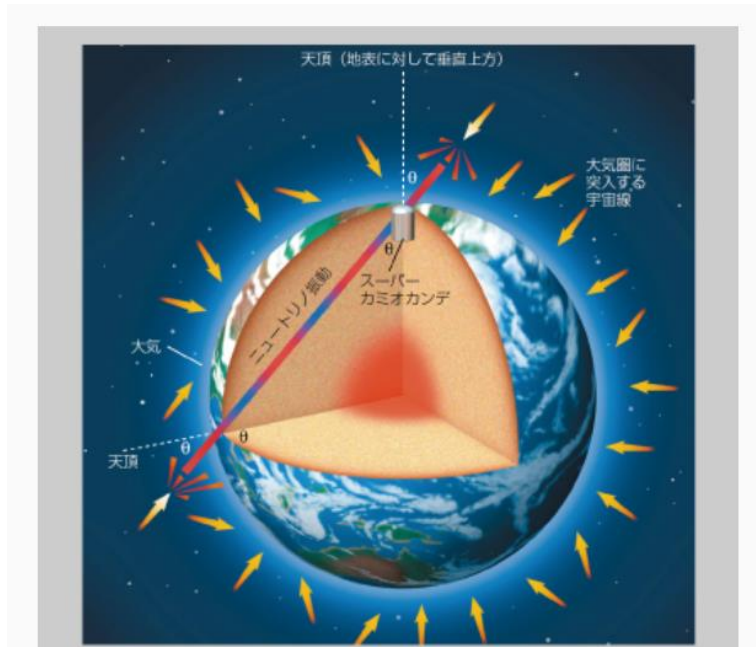

Slide in Neutrino 1998

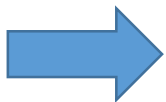

Prof. Kajita got Nobel prize in 2015 !

2001 Implosion accident

Barrel

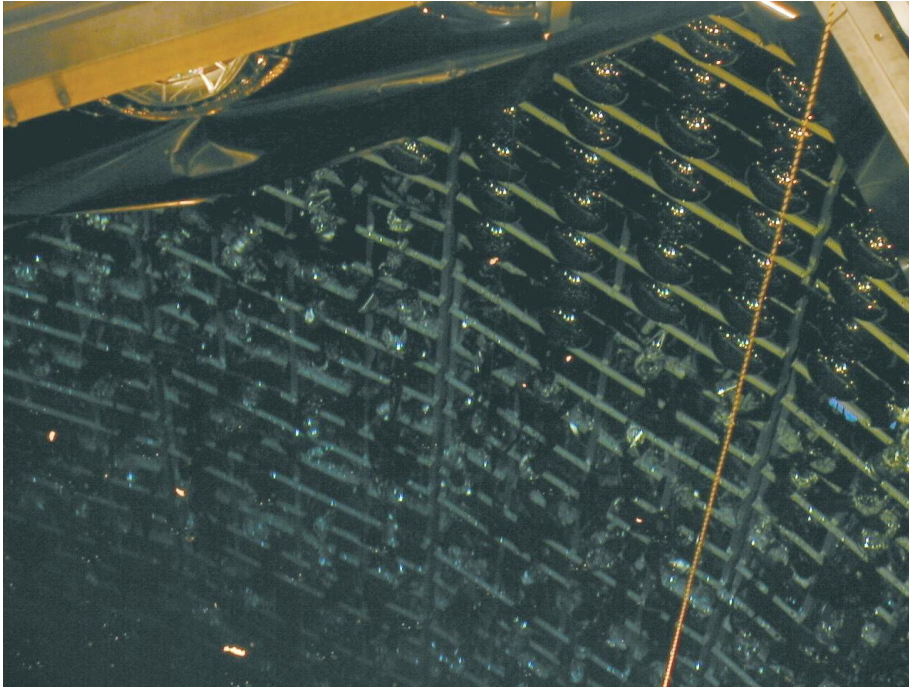

Bottom



About a half of PMT (~6000) were broken

What happened ?



- Inside of photomultiplier tube (PMT) is vacuum.
- One of PMT in the bottom was crashed (unknown cause).
- Water came into inside and made big shockwave due to high water pressure.
- The shockwave destroyed neighbor PMTs.
- The chain reaction destroyed many PMTs.

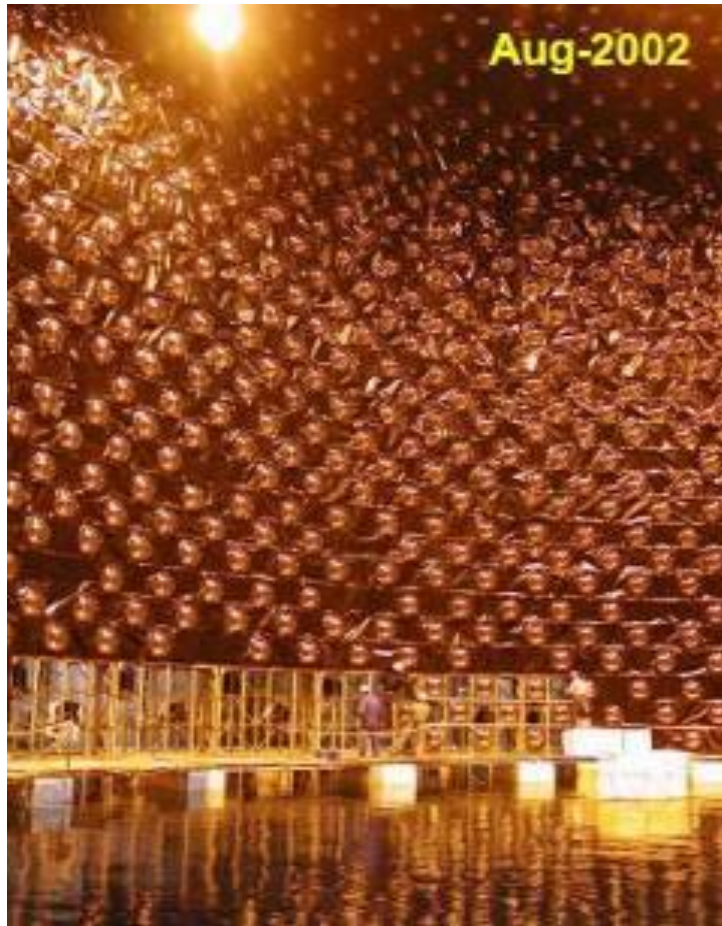

Our boss, Totsuka said “There is no question. We will reconstruct SK !”.



Acrylic (front)
+ FRP (back)

It was miracle that we reconstructed SK with remaining 5182 ID PMTs just in one year.

3. Studies in SK: Atmospheric ν

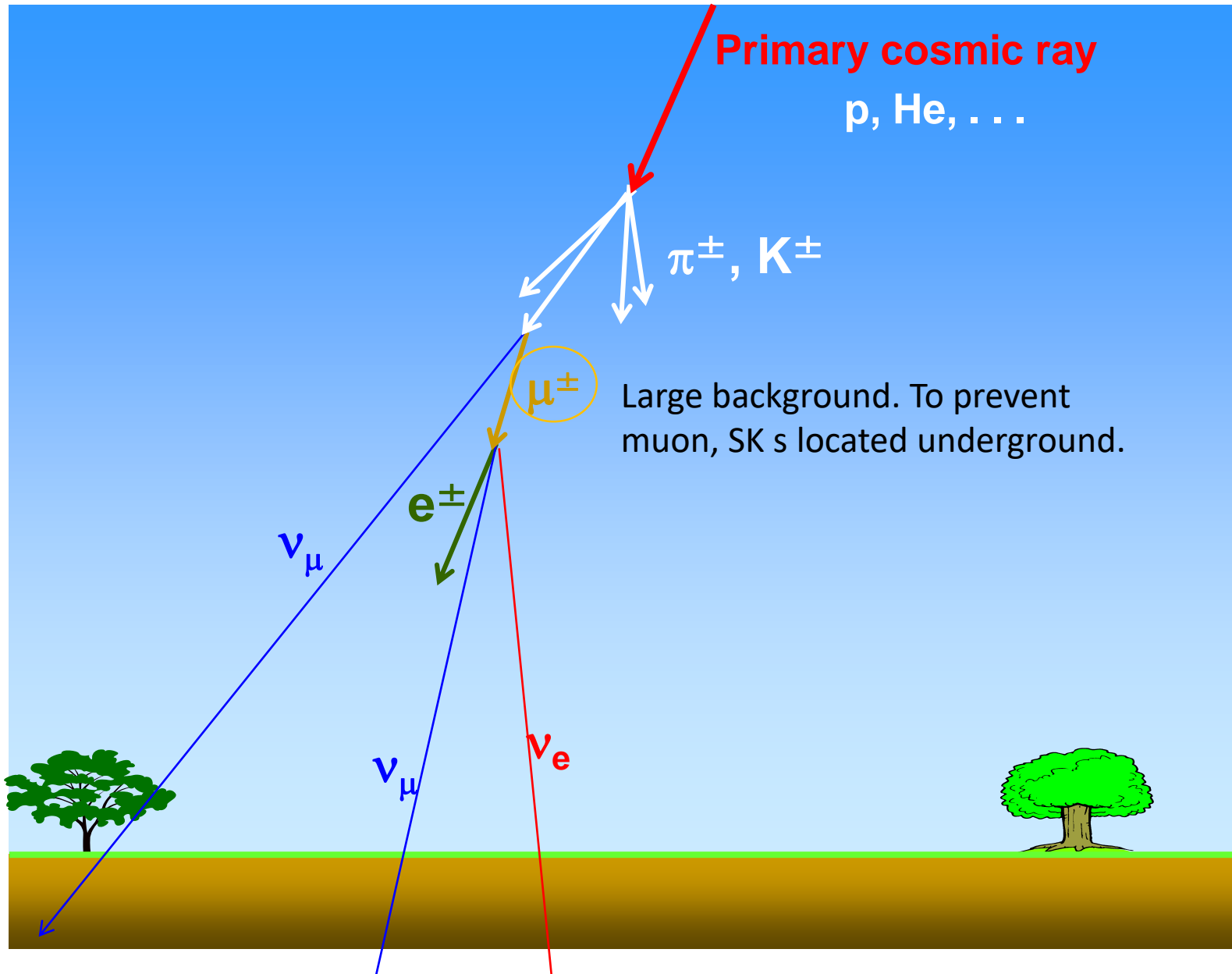

Solar ν

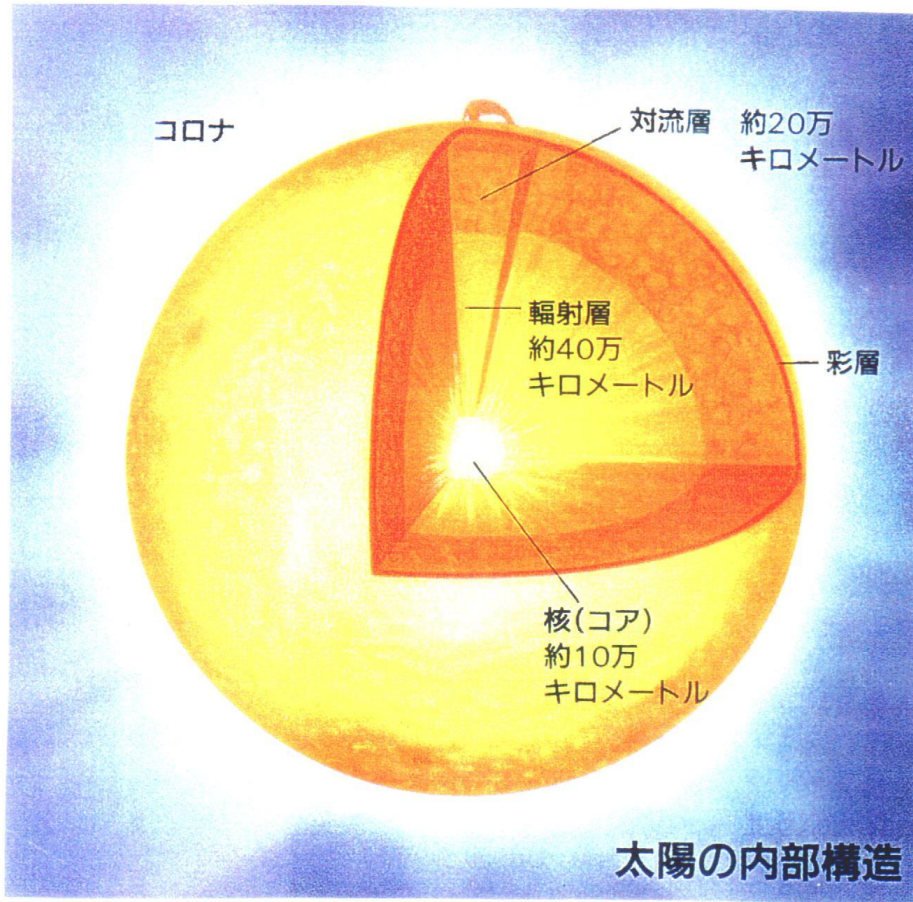

Large number of neutrino:
 $\sim 6 \times 10^{10} \nu_e / \text{sec} / \text{cm}^2$

Good information to know
what is going on inside of the
solar.

Super Nova ν

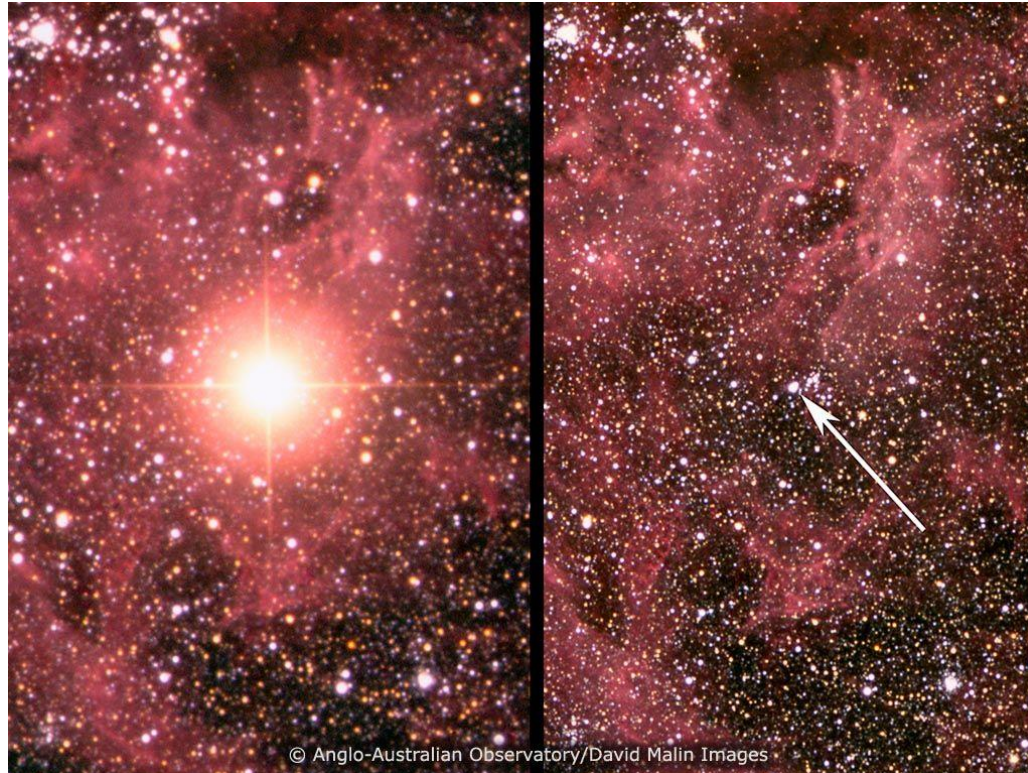

Neutrinos carry $\sim 99\%$ of energy at Super Nova .
They gives us information how SN happens.

Proton decay

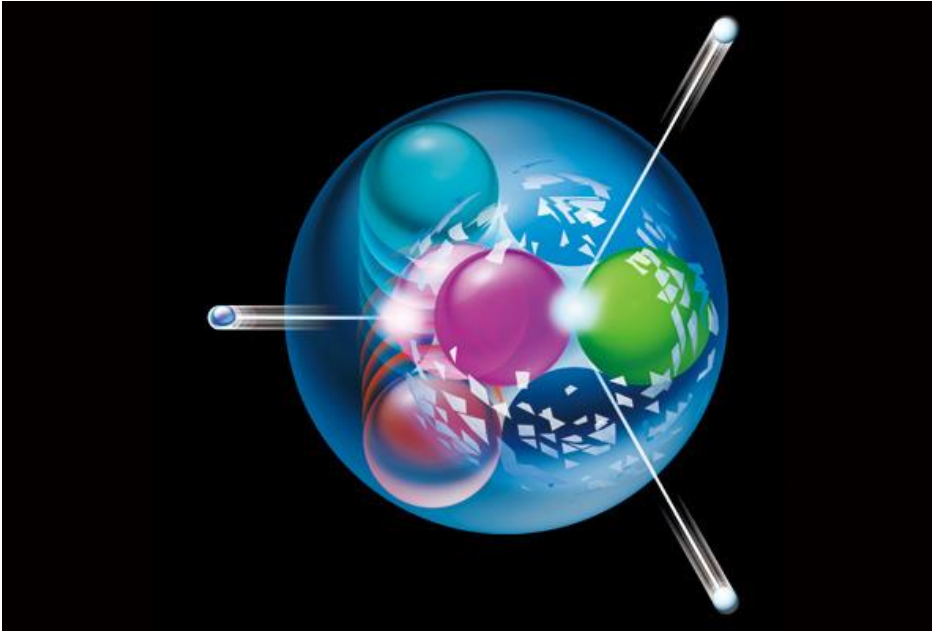

- It is a key to **beyond Standard Model**.
- $p \rightarrow e^+ \pi^0$ and $p \rightarrow \nu K^+$ are dominant modes.
- **It may bring the 3rd Nobel prize to Kamioka.**
- More details will be given in the next week.

Accelerator ν

NEXT GENERATION LONG-BASELINE
NEUTRINO OSCILLATION EXPERIMENT

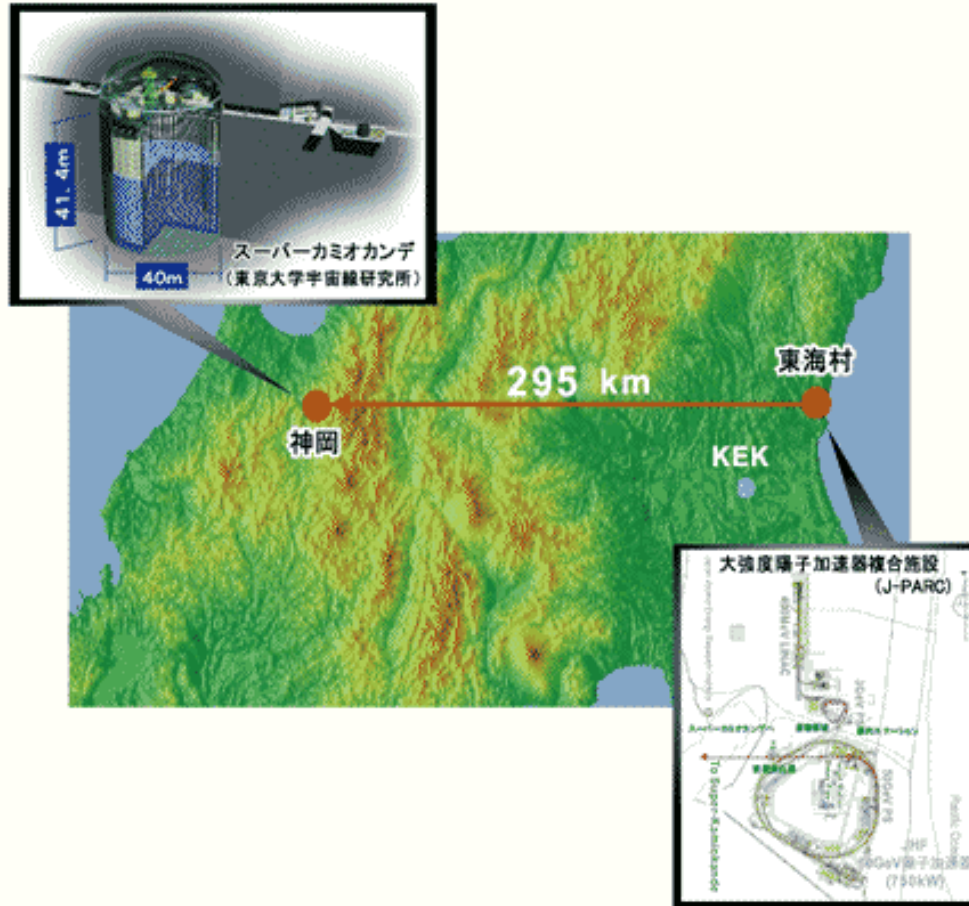

Shot ν made by accelerator to SK at 295km far away to investigate neutrino oscillation precisely.

4. Opening new era ! : SK-Gd

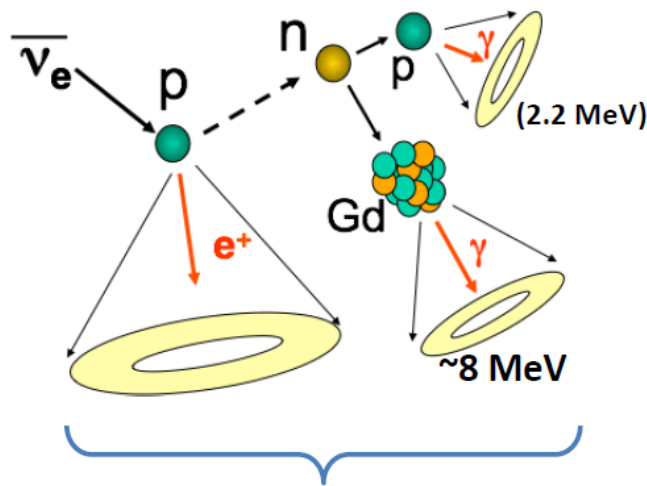

- Reduce BG of ν_e -bar signal
 - Delayed coincidence
 - $\Delta T \sim 30 \mu s$
 - Vertices within $\sim 50 \text{ cm}$

- SK used Ultra-pure water
 - Quasi-elastic scattering:
 $\nu_e n \rightarrow e^- p$
 $\bar{\nu}_e p \rightarrow e^+ n$
 - SK can't identify charge.
 - But if we put Gd into water, we can separate neutrino and anti-neutrino reaction by 8 MeV γ from neutron capture of Gd.
- ➔ SK-Gd project

- Benefit of SK-Gd
 - Increase sensitivity for super nova neutrino
 - Better sensitivity CP violation in neutrino oscillation
 - Reduction background events for proton decay.
 - And so on.
- *Before Gd loading, we have to stop water leak.*
 - Leak rate: $\sim 1\text{ton/day} = 700\text{ml/min}$, not so much.
 - Wastewater from Kamioka mine which include cadmium (Cd) flowed into river and it caused “Itai-itai disease” until 1970’s.
 - How Gd affects on human health has not been reported, and we will use 0.1 % Gd concentration.
 - However, local people are very sensitive to this kind of problem.
 - We decided to open SK tank to fix water leak, and also replace bad PMTs from June 2018.

So, SK story continues.....



Stop data taking.
Start to repair tank

Fill up water.
Close tank

Start dissolving Gd

Finish tank work.
Start filling water

Operation with
pure water (SK-V)



SK-Gd started !

Super-Kamiokande in 2018

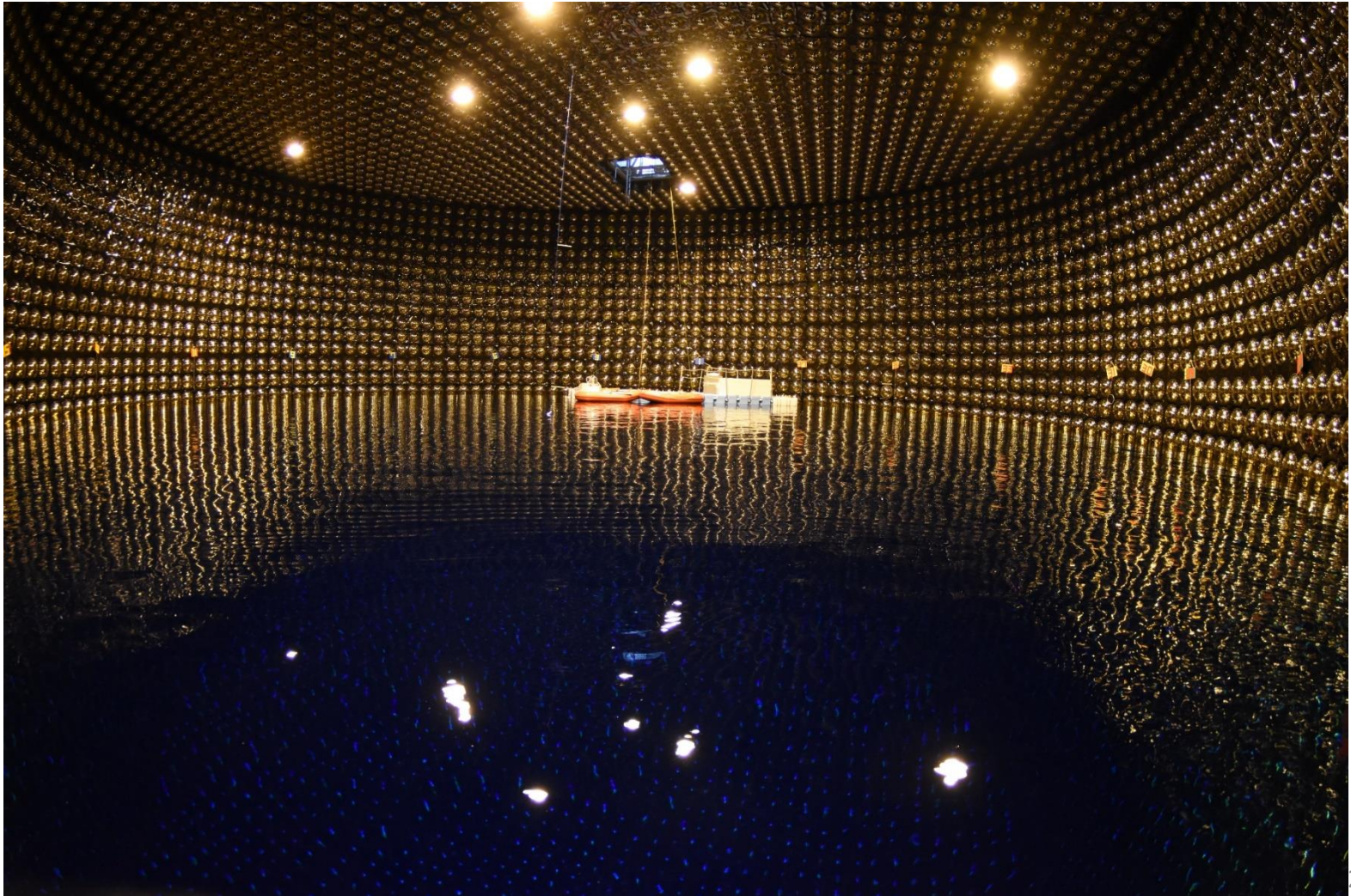

Outer wall of SK tank



SK tank wall is made of stainless steel plates (2m x 8m) connecting by welding each other.



We assume water leaks from welding part and decided to seal all welding lines.



In this chance, we replaced bad PMTs (~130).
PMT replacement 1: prepare PMT module



Cleaning PMT and check glass surface.



Attach PMT cover.

PMT replacement 2: Attach to tank



Working on floating floor

Removing bad PMT



Attach new PMT



- ~ 30 researchers worked for this work everyday
- The work continued until middle of September, 2018.
- Start to fill water from October, and finished filling in January, 2019.
- **We confirmed water leak has been stopped !**
- After many calibration works in February, 2019 and March, we resumed data taking with pure water.
- **We made sure reproducibility of the detector !**
 - Going to add Gd in February 2020,
 - However

Fight against COVID-19

- COVID-19 spread all over the world in this spring ...
 - Non-Japanese member could not come to Japan.
 - Even Japanese members could not moved to Kamioka.
 - ➔ Suspended Gd dissolving to water.
- Japanese situation was getting better in June.
 - Most of Japanese institutes allowed to trip to Kamioka.
 - We decided to cover all Gd dissolving work by Japanese only.
- We started Gd work from July and finished the work in August, 2020.
 - ➔ SK-Gd project started !

Evolution of Super-K: SK-Gd

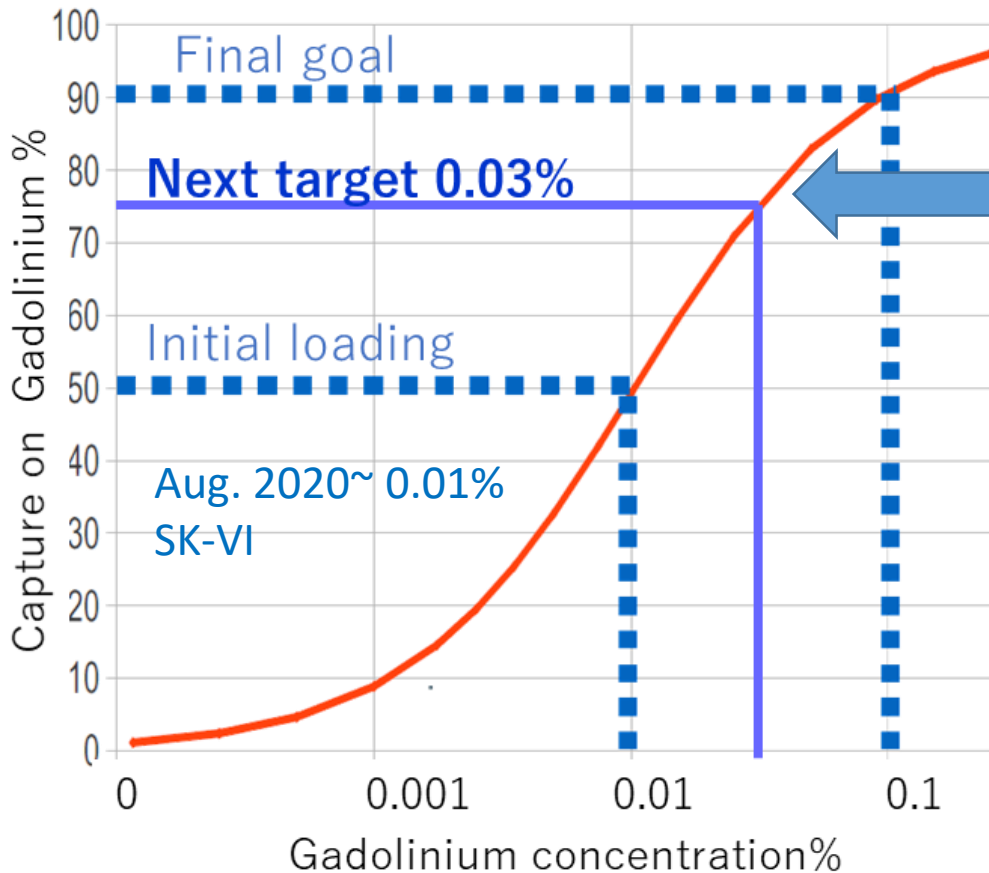

We added more Gd and finished dissolving on July 5th, 2022 !
SK-VII started !

SK-VI Neutron Capture Signal on Gd

- Compared to **H**, neutron captures on **Gd** are:

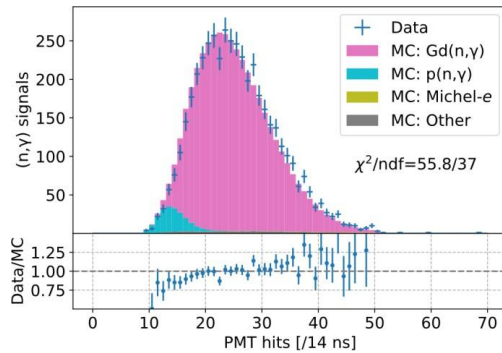
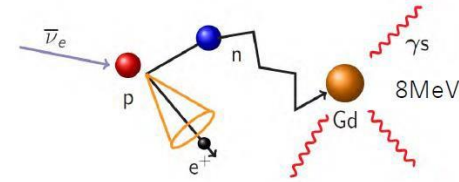

more energetic

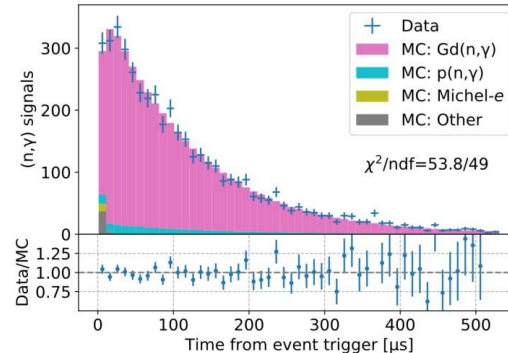

shorter lived

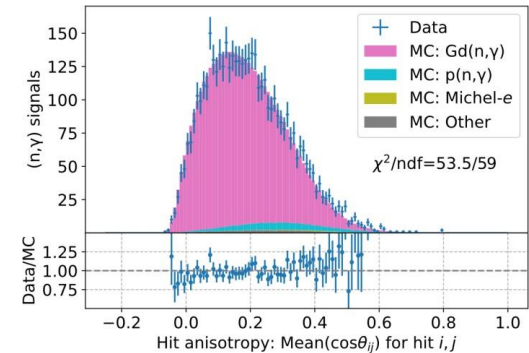

more isotropic

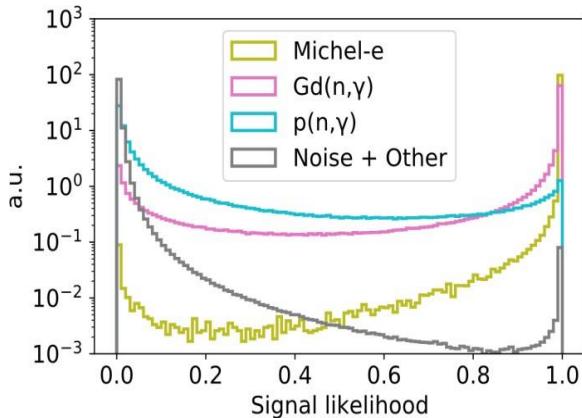

- Neural network to select neutron candidates
- Cuts to remove remaining **Michel electrons**

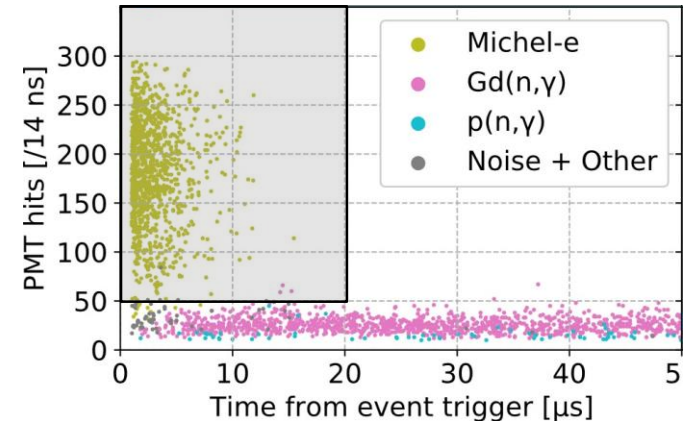

5. Key technology

How neutrino can be detected in SK?

- Neutrino has small mass and neutral particle. **Neutrino itself can not be seen**, but it rarely interacts with nucleon or electron. Ex. $\nu_e n \rightarrow e^- p$.
- **Kicked out charged particle emits Cherenkov light** in water.
- Cherenkov light propagates in water and it is detected by PMT.
- From amount of light and arrival time, vertex, direction, particle type and momentum of charged particle can be obtained.
- From those information, **we can obtain information of neutrino.**

ν_e : Invisible

e^- : Charged particle

Oxygen

Cherenkov light

Photo sensors

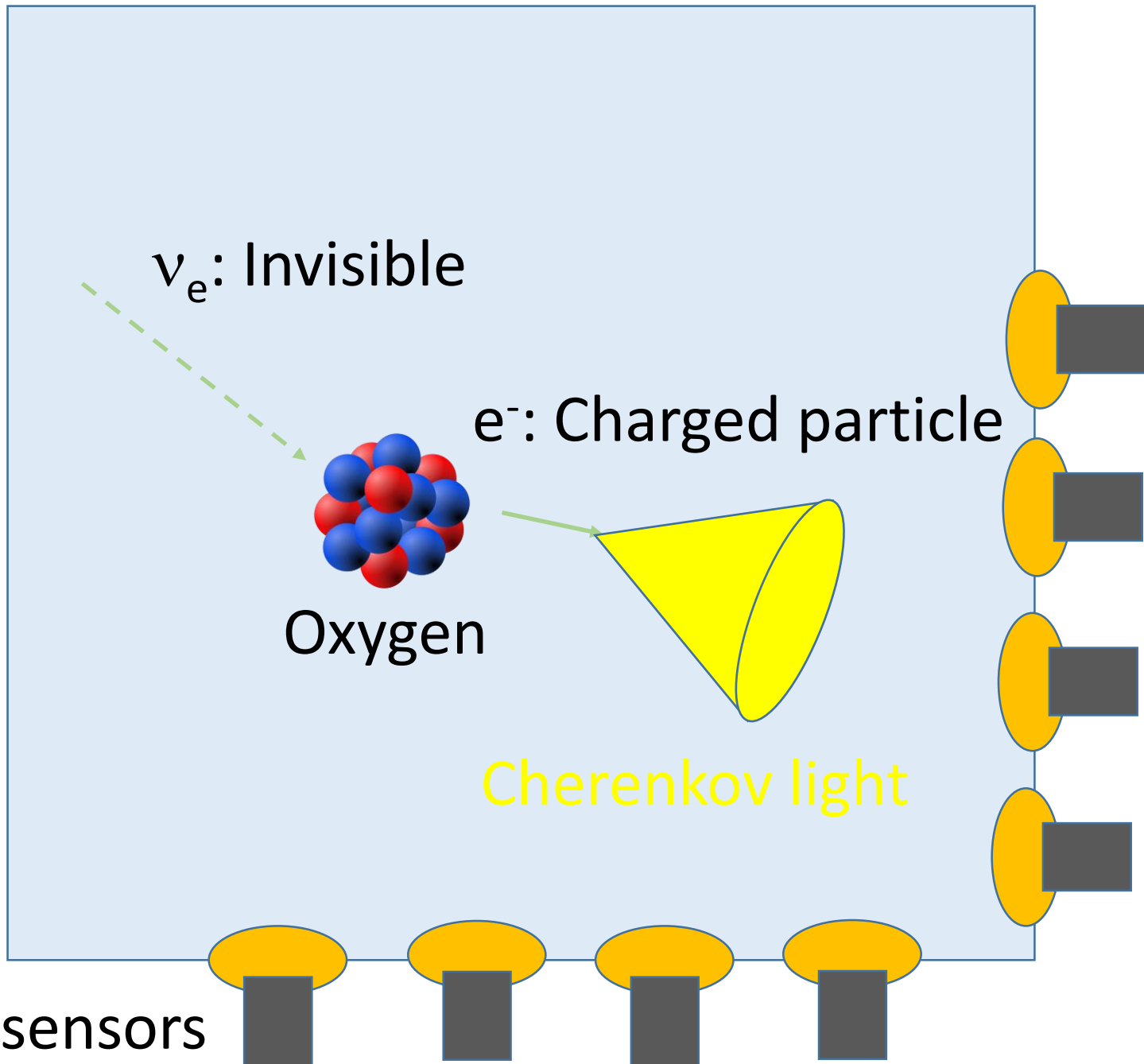

- So, roughly say, SK is made of;
 - Tank
 - Water
 - Photo detector (PMT)
 - Readout electronics

5-0. Cherenkov light.

- Cherenkov light emission: Electromagnetic phenomena.
 - Similar to sonic boom.
- It happens a charged particle moves faster (β) than light velocity in the medium, c/n .
 - c : velocity of light in vacuum,
 - n : reflective index of the medium

- $$\cos \theta_c = \frac{1}{n\beta}$$

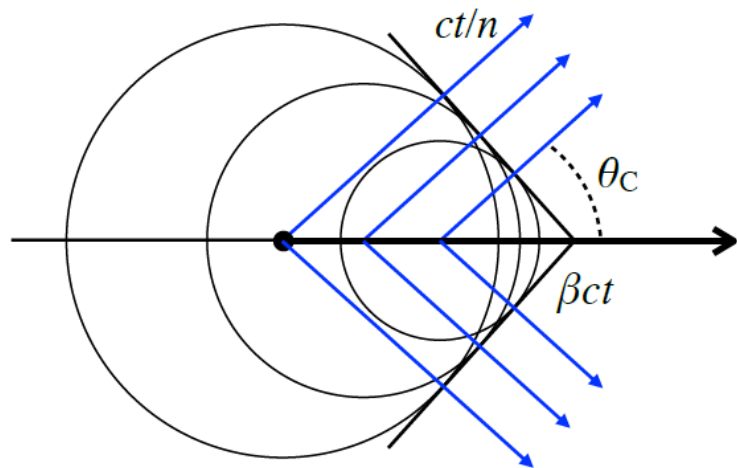

$$\cos \theta_c = \frac{1}{n\beta}$$

- Water: $n=1.34$, $\beta \sim 1 \rightarrow \theta_c \sim 42^\circ$

$$\beta \geq \frac{1}{n}$$

- The condition to emit Cherenkov light (Cherenkov threshold) for electron: $> 0.57 \text{ MeV}/c$

(Excise)

Calculate Cherenkov threshold for μ ($m_\mu=106 \text{ MeV}/c^2$) and π ($m_\pi=140 \text{ MeV}/c^2$).

Hint: $p=m\beta\gamma = m\beta/\text{sqrt}(1-\beta^2)$

NOTE: Heavier particle has smaller θ_c with same momentum.
 \rightarrow Used in particle identification.

5-1. Tank

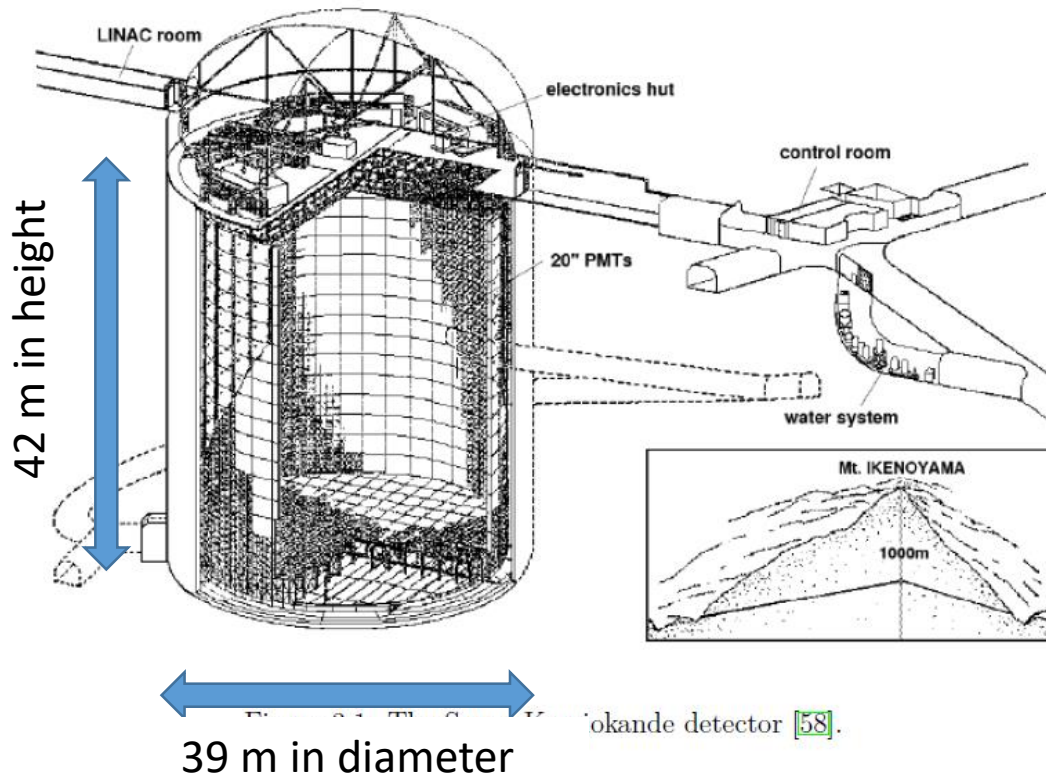

- Located ~1000 m below mountain peak. The mountain acts as filter for cosmic muons

Contain 50 k ton water !

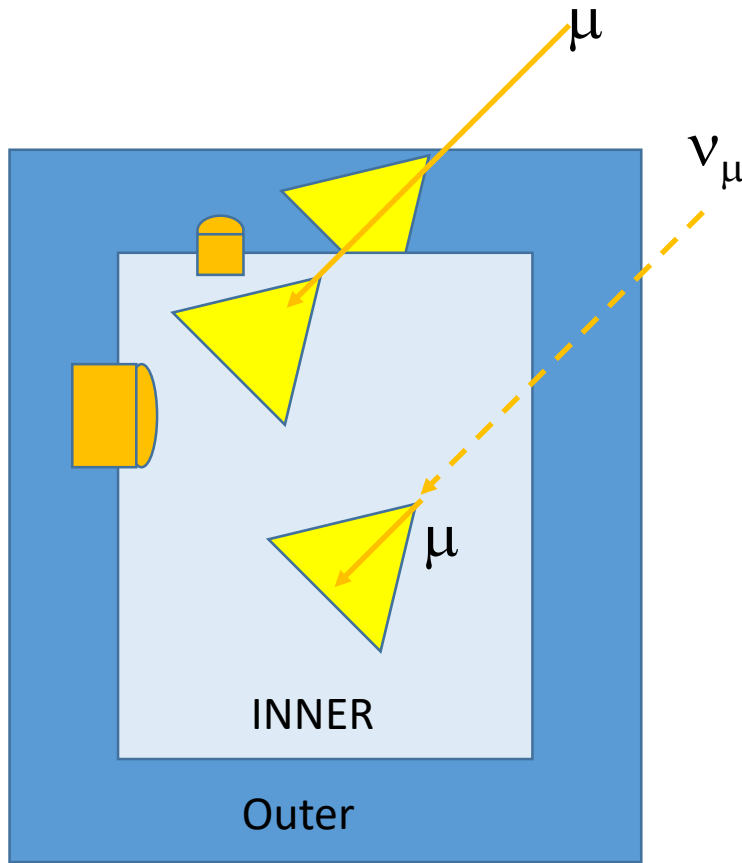

On the other hand, ν which interacts inner doesn't have photon in outer layer.

- Even 1000 m underground, cosmic ray muons reach to SK (~several tenth Hz).
- SK is optically divided into two layer (inner and outer).
- PMTs are attached on inner wall.
- 20 inch PMTs are facing inward and 8 inch PMTs are outward.
- Cosmic ray muon can be rejected because it produces photons in outer layer.

5-2. Water system

- SK is filled by 50 kton **ultra pure water**.
 - The source is spring water in the mine which contains radio active materials (dominant: Radon). They are tremendous background in low energy region.
 - Cherenkov light is affected by absorption and scattering in water. Light is decreased as:

$$I = I_0 \exp\left(-\frac{x}{L_{Atn}}\right)$$

where L_{Atn} is attenuation length (~ 100 m at SK).

- Water is circulated all the time, filled from the bottom and drain at the top. To prevent convection and bacteria, filling water temperature should be well controlled at 13.06 degree.

Temperature control is important for water quality

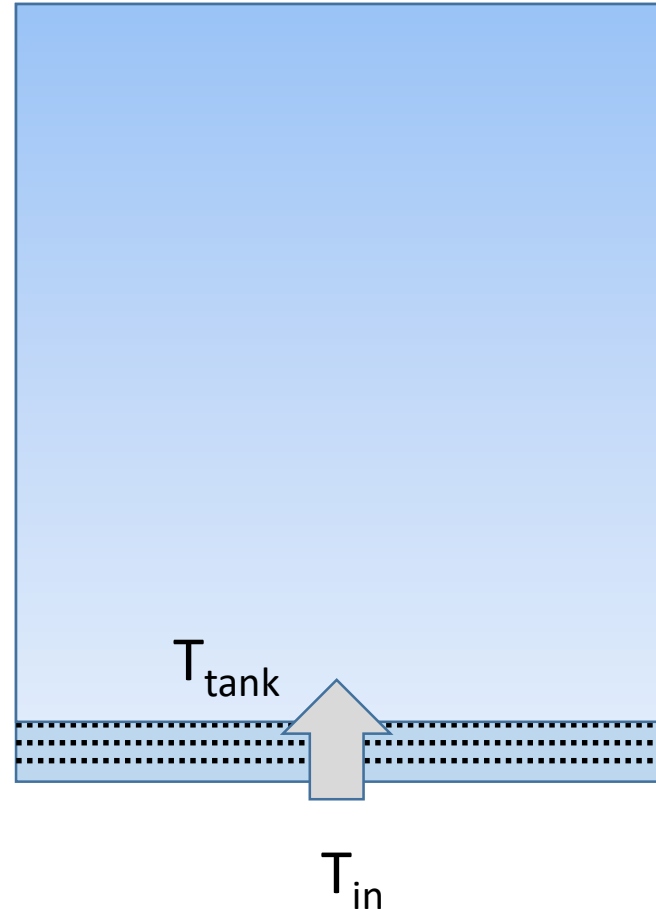
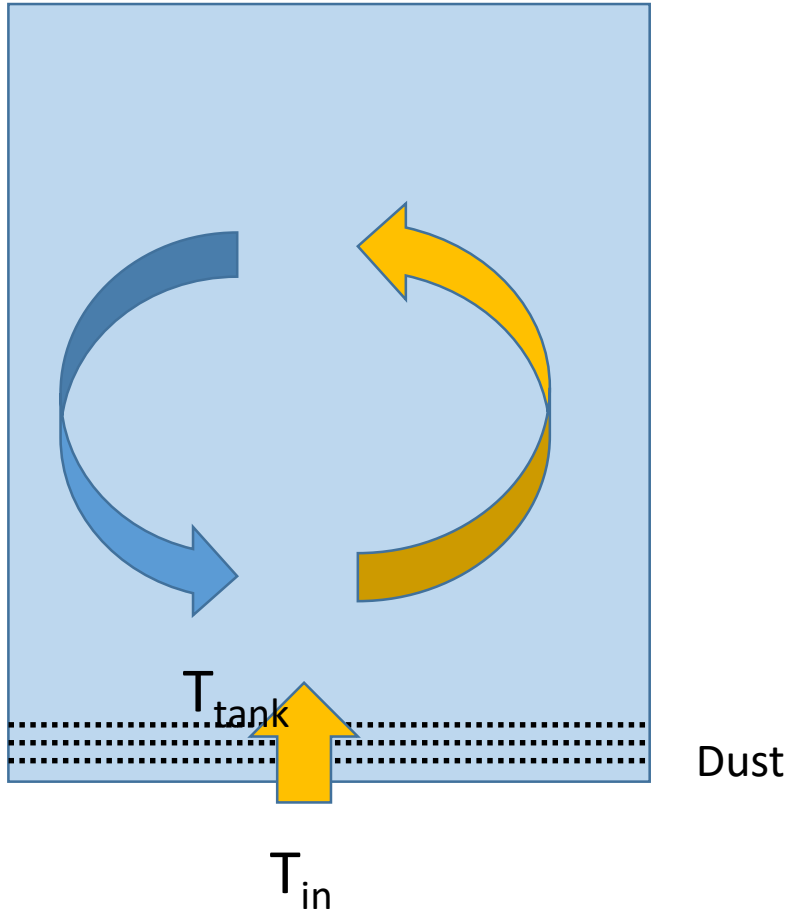

- $T_{\text{in}} > T_{\text{tank}}$: Convection happens.
→ Dust in bottom is stirred up.
→ Worse water quality.

- $T_{\text{in}} < T_{\text{tank}}$: Laminar and water raised up quietly..
→ Better water quality

5-3. Photomultiplier tube (PMT)

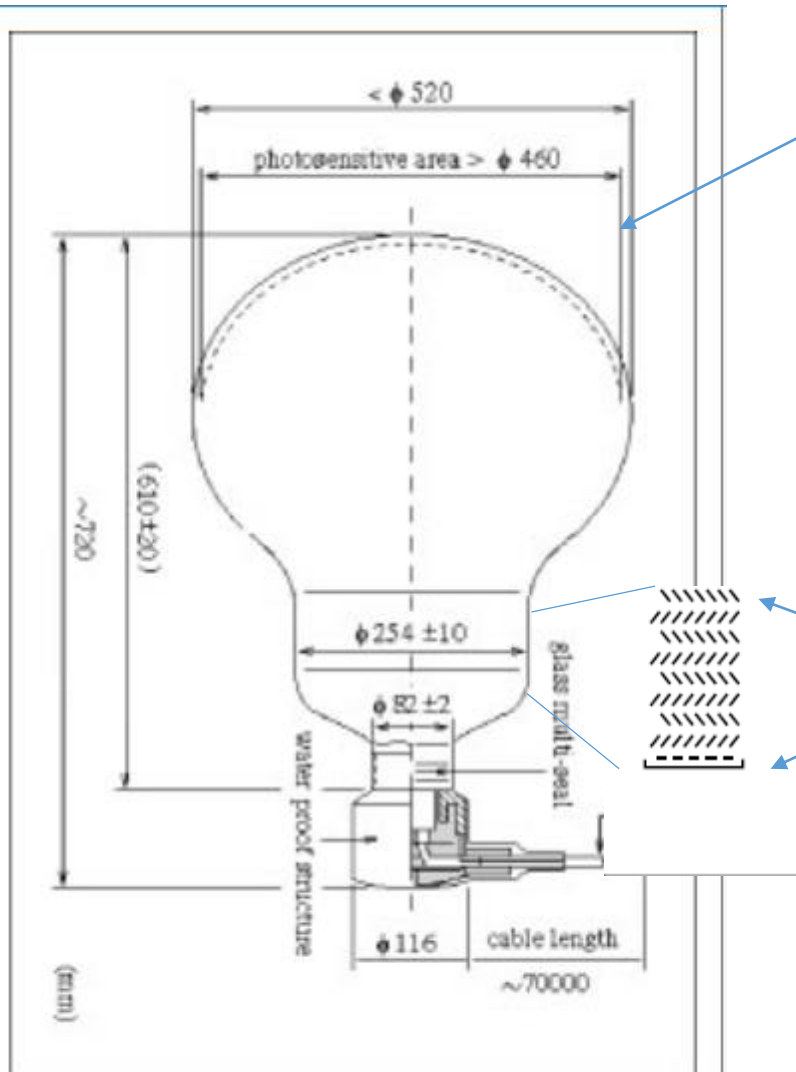

- **Photo cathode:** Glass covered by biarkari and a photon is converted to electron (so called photoelectron) with $\sim 20\%$ efficiency (quantum efficiency or QE).
- Between anode and cathode, ~ 2000 V HV is applied. Photoelectrons are accelerated and hit first dynode and produce secondary electrons. There are several dynodes and repeat the process to achieve high gain ($\sim 10^7$).

Shape	Hemispherical
Photocathode area	50 cm diameter
Window material	Pyrex glass (4 ~ 5 mm)
Photocathode material	Bialkali (Sb-K-Cs)
Quantum efficiency	22 % at $\lambda = 390$ nm
Dynodes	11 stage Venetian blind type
Gain	10^7 at ~ 2000 V
Dark current	200 nA at 10^7 gain
Dark pulse rate	3 kHz at 10^7 gain
Cathode non-uniformity	< 10 %
Anode non-uniformity	< 40 %
Transit time	90 nsec at 10^7 gain
Transit time spread	2.2 nsec (1σ) for 1 p.e. equivalent signals
Weight	13 kg
Pressure tolerance	6 kg/cm ² water proof

Table 2.1: Specifications of 20-inch PMT.

Spectrum of Cherenkov light and QE

Reduce light due to scattering

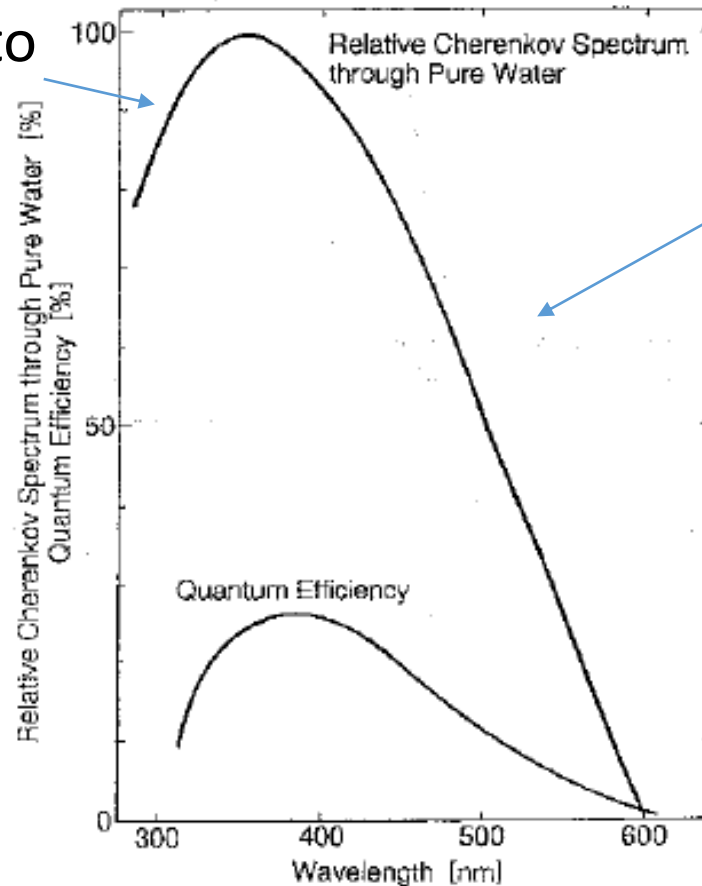

Reduce light due to absorption.

Quantum Efficiency of SK PMT is optimized to detect Cherenkov light

Typical response for one photon

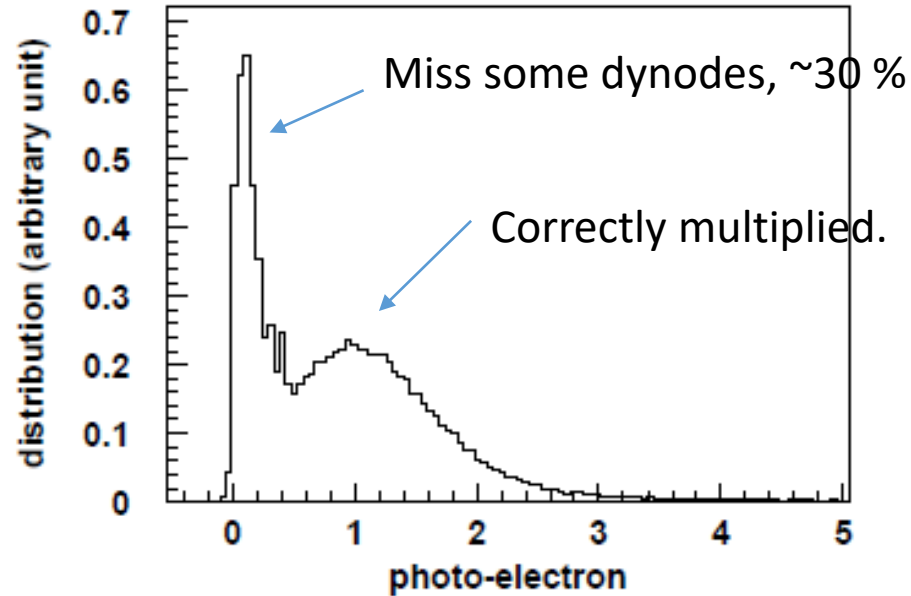

Figure 2.7: Single photoelectron distribution of a typical 20-inch PMT.

Photon \rightarrow Charge pulse

5-4. Electronics and readout

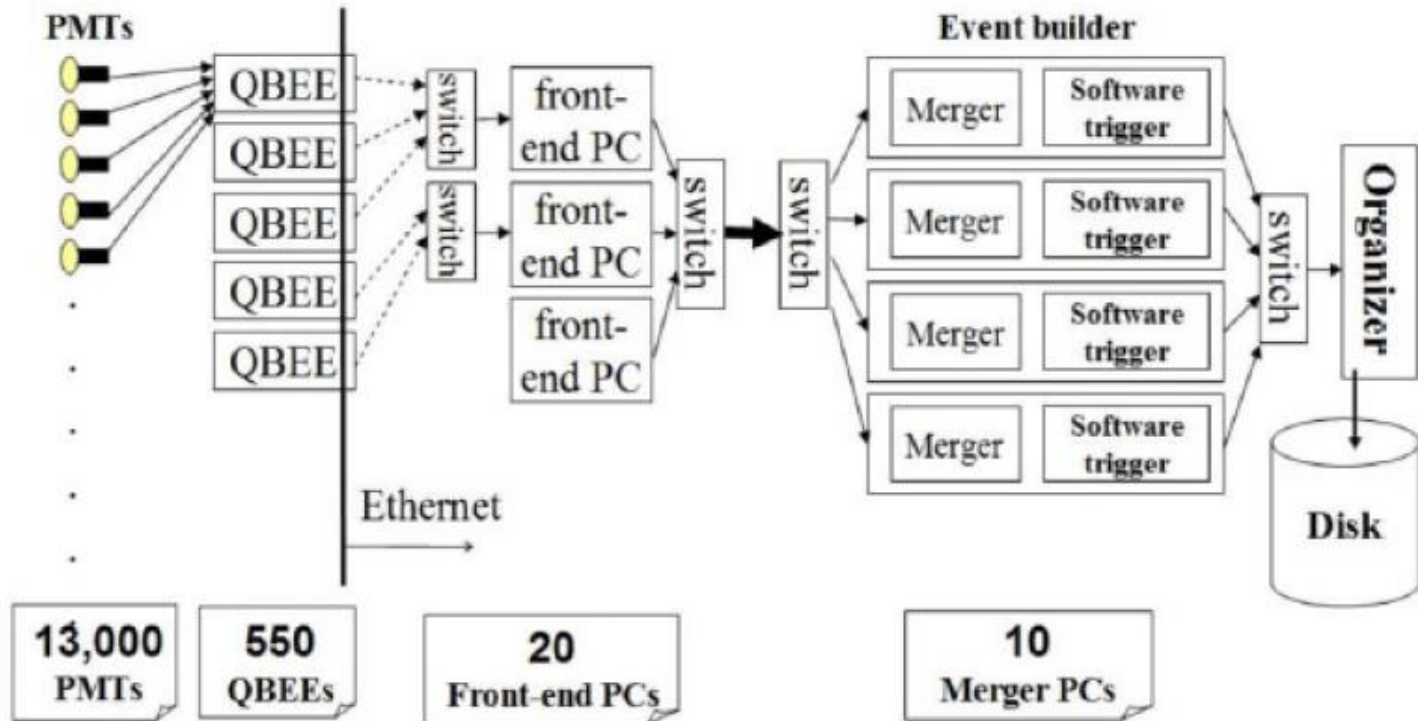
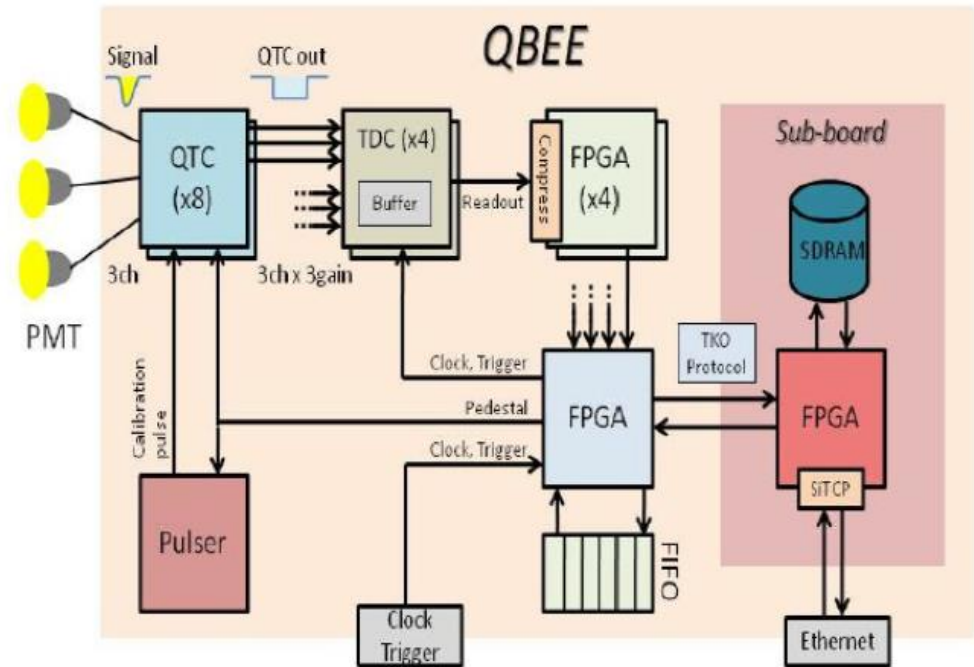
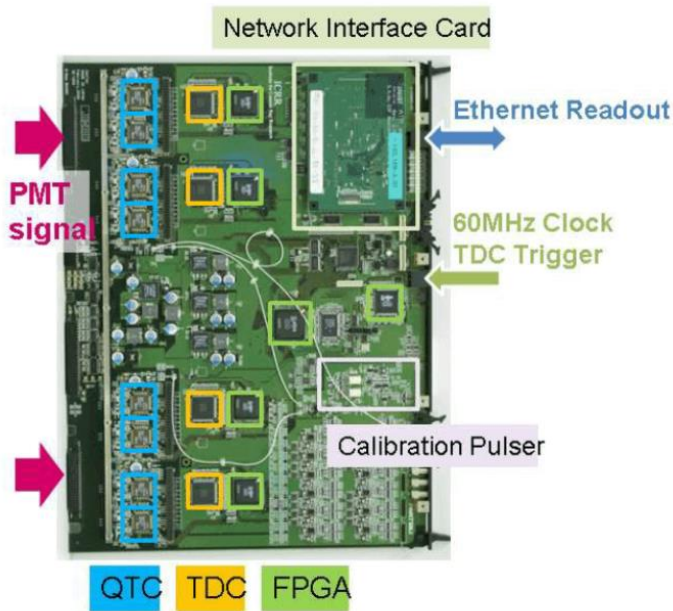
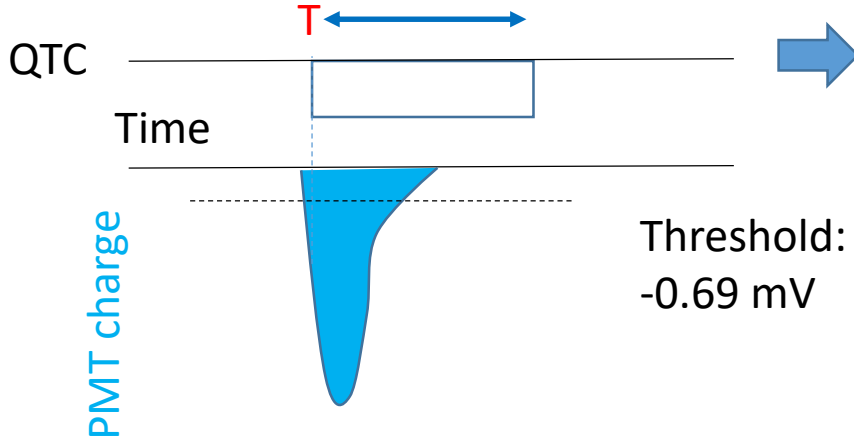

Figure 3.10: The schematic view of the DAQ system used in SK-IV [97].

Electronics: QBee board



Width corresponding to integrated Q in 400ns



Time-to-Digital-Converter

Q

Make digitized T and Q for each PMT
 → Send to Front PC via ethernet

- Front-end PC
 - Sort PMT data by time. Send to Merger PC.
- Merger PC: apply software trigger
 - Count number of hits in 200 ns (N_{200}). If it exceed threshold, make trigger
 - Define a event as hit cluster with time window for each time window. Events are save in disks.

Table 3.6: The threshold for each trigger and its event time width.

Trigger Type	Threshold for N_{200} [hit PMTs]	Event timing width [μs]
SLE	34 \rightarrow 31 (After May 2015)	1.5 ($-0.5 \sim +1.0$)
LE	47	40 ($-5 \sim +35$)
HE	50	40 ($-5 \sim +35$)
SHE	70 \rightarrow 58 (After September 2011)	40($-5 \sim +35$)
OD	22 in OD	40 ($-5 \sim +35$)

6. Introduction of software training: Particle Identification (PID)

- Electron/ gamma case
 - It makes electromagnetic shower and make many e^- and e^+ .
 - Each of them makes Cherenkov light.
 - Thus, ring pattern becomes defused.
- Muon/ pion case
 - Doesn't make electromagnetic shower.
 - Ring edge becomes rather sharp.
 - In smaller momentum, Cherenkov angle becomes less than 42° because of low β .

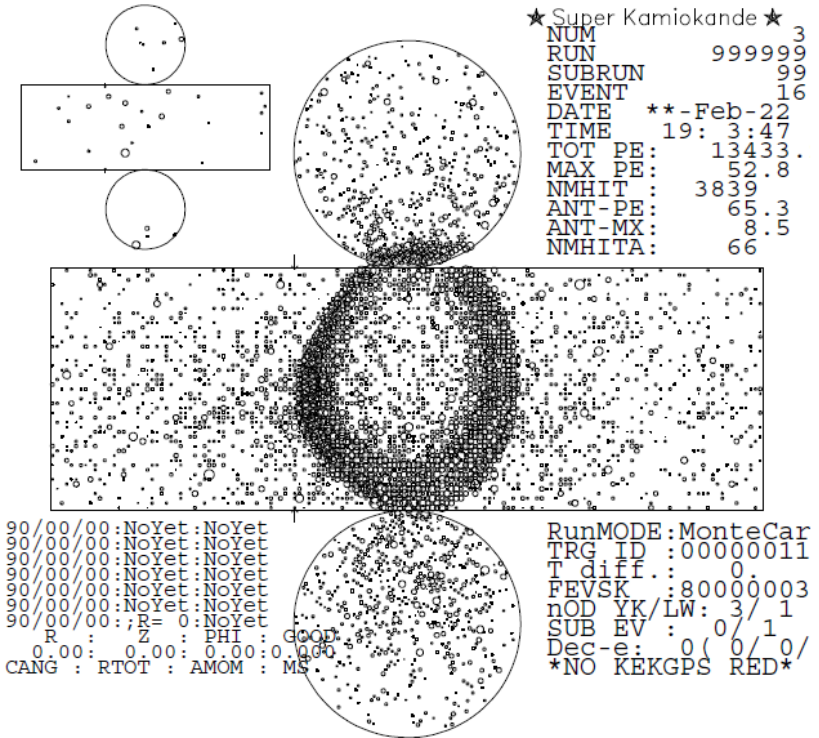
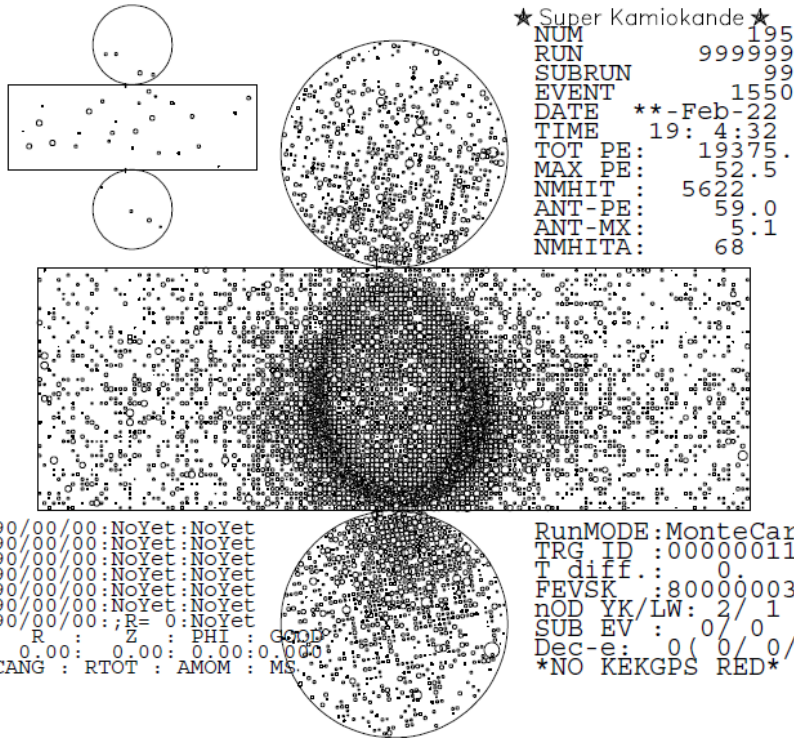

Comnt;

Comnt;

Can you identify electron and muon by your eyes ?

To be continued to software training